



**FITTING INSTRUCTIONS FOR LP0310BK**  
**LICENSE PLATE BRACKET**  
**YAMAHA MT-09 STANDARD & SP 2021-**



**THIS KIT CONTAINS THE ITEMS PICTURED AND LABELLED OVER PAGE.**

SOME PARTS MAY BE SHOWN FOR CLARITY OF INSTRUCTIONS ONLY.

DO NOT PROCEED UNTIL YOU ARE SURE ALL PARTS ARE PRESENT.

**PLEASE READ ALL INSTRUCTIONS BEFORE PROCEEDING.**

**IF IN ANY DOUBT WHEN FITTING OUR PRODUCTS, CONSULT ONE OF OUR DEALERS  
OR HAVE FITTED BY A QUALIFIED TECHNICIAN.**

PLEASE NOTE THAT THE WAY THE KIT IS PACKED DOES NOT NECESSARILY REPRESENT THE WAY OF  
MOUNTING TO THE BIKE.

IN THE EVENT OF RUBBER WASHERS BEING USED TO HOLD COMPONENTS ONTO BOLTS,  
THESE RUBBER WASHERS CAN BE THROWN AWAY.

**DIGITAL COPIES OF THESE INSTRUCTIONS ARE AVAILABLE FROM:**

**[WWW.RG-RACING.COM](http://WWW.RG-RACING.COM)**



<b><u>TOOLS REQUIRED</u></b>	<b><u>GENERAL TORQUE SETTINGS</u></b>
<ul style="list-style-type: none"> <li>• HEAT GUN OR LIGHTER</li> <li>• ¼" DRIVE SOCKET SET</li> <li>• CLIPPERS</li> <li>• ALLEN KEY SET</li> <li>• SMALL FLAT HEAD SCREWDRIVER</li> </ul>	M4 BOLT = 8Nm M5 BOLT = 12Nm M6 BOLT = 15Nm M8 BOLT = 20Nm M10 BOLT = 40Nm M12 BOLT = 40Nm

### **LEGEND**

<b>ITEM NO.</b>	<b>DESCRIPTION</b>	<b>QTY</b>
ITEM 1	TB0310 PART 1 NUMBER PLATE BRACKET	1
ITEM 2	TB0310 PART 2 (COVER PLATE)	1
ITEM 3	RB0004 RUBBER BUNG	1
ITEM 4	LA0002 NUMBER PLATE LIGHT (W/SHROUD)	1
ITEM 5	M6x1.00x30mm BUTTON HEAD BOLTS OR M6x1.00x35mm COUNTER SUNK BOLTS (PICTURE 11 & 12)	4
ITEM 6	M6x19mmØ FLAT WASHERS OR M6X22mmØ COUNTER SINK (PICTURE 11 & 12)	4
ITEM 7	M6x1.00mm NYLOC NUTS	4
ITEM 8	S0384 M6x6.00mm SPACERS	4
ITEM 9	666-896 180mm LENGTH OF HEAT SHRINK	1
ITEM 10	CT220 205mm CABLE TIES	2
ITEM 11	IWC0002 MINI INDICATOR WIRING COVERS	2
ITEM 12	CLIP1 SELF ADHESIVE CABLE CLIPS	4
ITEM 13	I0016 INDICATOR ADAPTERS	4
ITEM 14	I0037 OEM INDICATOR ADAPTERS	2
ITEM 15	CON0034 OEM INDICATOR CONNECTORS	2
ITEM 16	CON0077 LICENCE PLATE LIGHT BULLET CONNECTORS	1
ITEM 17	REFL3 REFLECTOR	1

R&G Racing

Unit 1, Shelley's Lane, East Worldham, Alton, Hampshire, GU34 3AQ

Tel: +44 (0)1420 89007 Fax: +44 (0)1420 87301 [www.rg-racing.com](http://www.rg-racing.com) Email: [info@rg-racing.com](mailto:info@rg-racing.com)



ITEM 18	RGS0001 LARGE STICKERS	2
ITEM 19	RGS0005 BUBBLE STICKERS	2
ITEM 20	FITTING INSTRUCTIONS QR CODE	1

**EXPLODED ASSEMBLY VIEW**

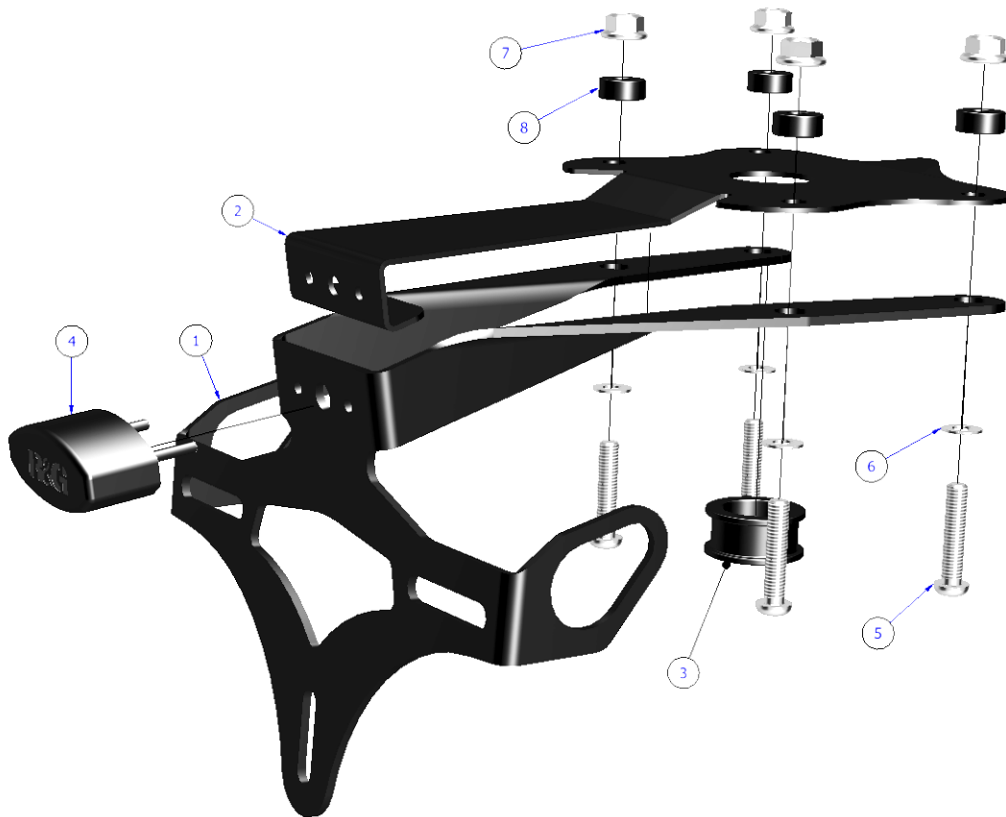

**FITTING PICTURES**



Picture 1



Picture 2



Picture 3



Picture 4



Picture 5



Picture 6



Picture 7



Picture 8



Picture 9



Picture 10

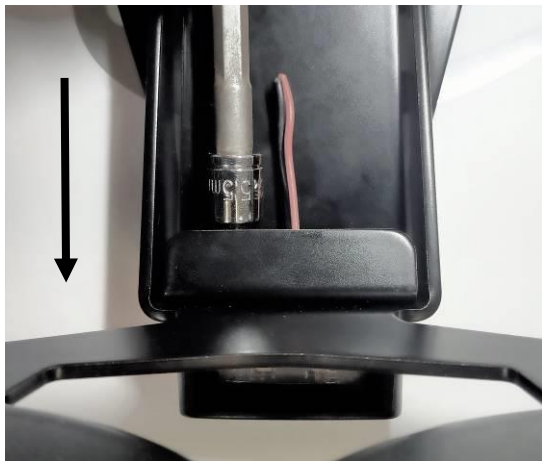

Picture 11



Picture 12



Picture 13 ALT



Picture 14 ALT

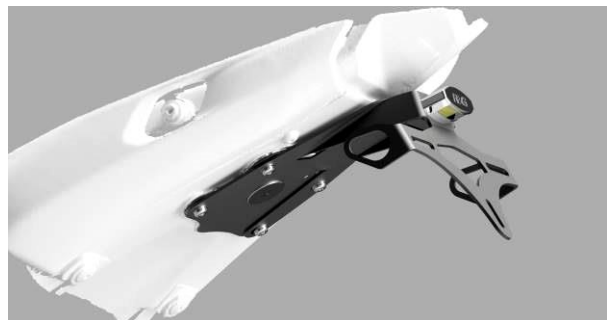
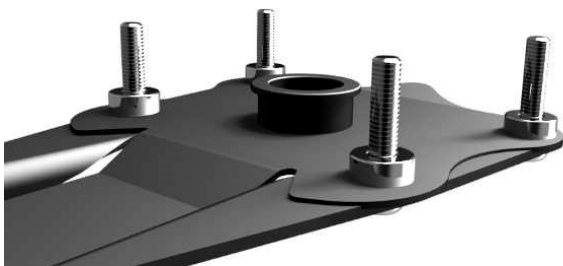





Picture 15



Picture 16



Picture 17



Picture 18



Picture 19

Picture 20



Picture 21

Picture 22



Picture 23

### **FITTING INSTRUCTIONS**

R&G Racing

Unit 1, Shelley's Lane, East Worldham, Alton, Hampshire, GU34 3AQ

Tel: +44 (0)1420 89007 Fax: +44 (0)1420 87301 [www.rg-racing.com](http://www.rg-racing.com) Email: [info@rg-racing.com](mailto:info@rg-racing.com)



### **Preparing The Assembly**

- Please follow the exploded assembly view above.
- Firstly, prepare the wiring on the licence plate light (**Item 4**) & indicators (if micro indicators are being fitted instead of OEM).
- Cut two small sections of heat shrink roughly 10-15mm in length for use later.
- Push the wires through the supplied heat shrink and apply heat until it can no longer be moved freely (**Picture 1**).

### **If fitting micro indicators**

As shown in **Picture 2** pass the wires through the indicator adapters (**Item 13**) followed by a flanged nut (**Item 7**), then the indicator wiring cover (**Item 11**).

- Pass one of the indicator adapters through the indicator bracket then sandwich the adapters around the bracket, push the threaded portion of the indicator through the assembly and thread the nut onto the indicator until tight (**Picture 3**)
  - Note: Do not fully tighten until assembled onto the motorcycle to allow angle adjustment.**
- Once tight, push over the indicator wiring cover (**Item 11**) followed by a small (10-15mm) section of heat shrink (**Picture 5**).
- Once the wiring cover (**Item 11**) is in position, fit the small section of heat shrink over the smaller end of the wiring cover then apply heat to fix in place (**Picture 6**).
- Connect **Item 15** to the bullet connectors on the micro indicators, then attach the other end to the connector attached to the motorcycle's wiring loom. (**Picture 7**)
- Repeat for the other indicator.

### **If fitting OEM indicators**

- The OEM indicators first need to be removed from the OEM licence plate hanger by further dismantling the plate hanger.
  - Then remove the plate inside the OEM indicator. (**Picture 19 & 20**)
  - Once removed the indicator can be pulled through the mounting hole.
  - Take the supplied OEM Indicator Adaptor plates (**Item 14**) and fit one to each indicator rubber, as shown in **pictures 21 & 22**.
  - Locate the indicators through the indicator mounting hole (using diluted washing up liquid or similar) on the tail tidy assembly (placing the correct side indicator on the correct side of the tail tidy, as previously marked on the wiring), and re-fit the small plastic plate inside the rubber to securely mount the indicator, as shown in **picture 23**.
- Push the rubber bung (**Item 3**) through the centre hole of the cover plate (**Item 2**). (**Picture 10**)
  - Once the wires of the number plate light have been wrapped with heat shrink, pass them through the centre hole of both the number plate bracket (**Item 1**) & the cover plate (**Item 2**)
  - Then push the threaded studs through the two adjacent holes and fit one of the small washers included with the number plate light. (**Picture 9**)
  - Place one of the small nuts into a 5.5mm ¼" drive socket then place over the stud with the washer fitted. A micro ratchet will make this process easier but a ¼" drive with an extension bar fitted can also be used.
  - Turn the assembly so that the studs are vertical this will cause the nut to fall onto the stud while remaining inside the socket. (**Picture 11**)
  - Turn clockwise until the nyloc engages, then repeat on the other nut. (**Picture 12**)
  - Once both washers and nuts are partially threaded onto the studs, tighten until the nut bottoms out onto the cover plate (Do Not Overtighten).
  - Push the number plate light shroud onto the light.
  - Connect **Item 16** to the licence plate light via the bullet terminals, then connect the other end to the connector attached to the wiring loom of the motorcycle. (**Picture 8**)

R&G Racing

Unit 1, Shelley's Lane, East Worldham, Alton, Hampshire, GU34 3AQ

Tel: +44 (0)1420 89007 Fax: +44 (0)1420 87301 [www.rg-racing.com](http://www.rg-racing.com) Email: [info@rg-racing.com](mailto:info@rg-racing.com)



### **Disassembly Of The Standard Tail Unit**

- Firstly, remove the seat from the motorcycle by turning the key in the hole in the undertray.
- Using an allen key remove the four bolts circled green in **Picture 18**, followed by the bolts circled in red.
- Once removed, the seat lock bracket can be removed or moved aside allowing access to the OEM lighting connectors & tail unit fixture bolts.
- Using a small flat head screwdriver, carefully un-plug the OEM lighting connectors attached to the tail unit.
- Then remove the four bolts holding the OEM tail unit in place, circled green. (**Picture 18**)
- Once removed the tail unit will drop away from the bike and can be stored.

### **Fitting The R&G Tail Tidy**

- Please follow the exploded view on page 3.
- Push the bolts (**ITEM 5**) through the washers or countersunk spacers (**ITEM 6 Dependant on which kit has been supplied**) then through both the number plate bracket & cover plate. (**Picture 13 & 14**)
- Once through, add the spacers (**Item 8**) onto the bolts. The assembly should now look similar to **Picture 15**.
- Push the cables of the indicators & number plate light through the undertray so they can be connected later.
- Pass the threaded portion of the bolts through the holes in the motorcycle's undertray, holding your hand flat against the heads of the bolts to keep the assembly in position.  
**Note: To make this process easier, you may use tape or blu tack (or similar) to hold the bolts in place, then remove once the nuts have been partially threaded.**
- Once through, apply the nyloc nuts to the end of each bolt and tighten until secure.
- Once secure, switch on the motorcycle's ignition and test the indicator & licence plate light function.
- Pull the tail unit cables through into the undertray as much as possible then using the cable ties (**Item 10**) and self-adhesive clips (**Item 12**) see **Picture 4**, attach the cables to the inside of the tail bracket to keep them out of sight.  
**Note: Please clean the surface you will be applying the self-adhesive clips to with alcohol/solvent.**
- Re-fit the OEM seat lock bracket (**Picture 18**)
- Remove the number plate from the OEM tail unit then re-attach to the **R&G** tail tidy.
- Depending on local laws, a reflector may be required at the rear of the motorcycle. In this case, please apply the included reflector (**Item 17**) to the number plate (Do not obscure the characters).

#### **IMPORTANT:**

IF FITTING A FULL-SIZE LICENCE PLATE AND PLACING IT FAR DOWN ON THE LICENCE PLATE HANGER, THERE IS A SMALL CHANCE OF THE LICENCE PLATE HITTING THE BACK WHEEL UNDER HEAVY LOAD AND OVER LARGE BUMPS IN THE ROAD. IT IS YOUR RESPONSIBILITY TO CHECK FOR THIS POSSIBILITY AND TAKE AVOIDING ACTION. FAILURE TO CHECK THIS COULD RESULT IN SERIOUS INJURY.

ISSUE 4 - 03/08/2021 (TB)

#### **CONSUMER NOTICE**

The catalogue description and any exhibition of samples are only broad indications of the Products and R&G may make design changes which do not diminish their performance or visual appeal and supplying them in such state shall conform to the order. The Buyer acknowledges no representation or warranty (other than as to title) has been given or will apply to the Products other than those in R&G's order or confirmation and the Buyer confirms it has chosen the Products as being of merchantable quality and suitable for its particular purposes. Where R&G fits

R&G Racing

Unit 1, Shelley's Lane, East Worldham, Alton, Hampshire, GU34 3AQ

Tel: +44 (0)1420 89007 Fax: +44 (0)1420 87301 [www.rg-racing.com](http://www.rg-racing.com) Email: [info@rg-racing.com](mailto:info@rg-racing.com)





the Products or undertakes other services it shall exercise reasonable skill and care and rectify any fault free of charge unless the workmanship has been disturbed. The Buyer is responsible for ensuring that the warranty on the motorcycle is not affected by the fitting of the Products. On return of any defective Products R&G shall at its option either supply a replacement or refund the purchase money but shall not be liable if the Products have been modified or used or maintained otherwise than in accordance with R&G's or manufacturer's instructions and good engineering practice or if the defect arises from accident or neglect. Other than identified above and subject to R&G not limiting its liability for causing death and personal injury, it shall not be liable for indirect or consequential loss and otherwise its liability shall be limited to the amounts paid by the Buyer for the Products or the fitting or service concerned. These terms do not affect the Buyer's statutory rights.

**R&G RACING RETURNS POLICY (NON-FAULTY GOODS)**

Returns must be pre-authorized (if not pre-authorized the return will be rejected). Goods may only be returned direct to us if they were purchased direct from us (customer must prove if necessary). Otherwise to be returned to original vendor. Goods must be in re-sellable condition, in the opinion of R&G Racing. All returns are subject to a 25% restocking and handling fee (25% of the gross value exc. P&P – at the prevailing price at time of purchase). The customer must pay any and all carriage charges. No returns of discontinued products, unless within 14 days of purchase. This policy does not affect your statutory rights and does not refer to faulty goods.

R&G Racing

Unit 1, Shelley's Lane, East Worldham, Alton, Hampshire, GU34 3AQ

Tel: +44 (0)1420 89007 Fax: +44 (0)1420 87301 [www.rg-racing.com](http://www.rg-racing.com) Email: [info@rg-racing.com](mailto:info@rg-racing.com)